



Product Update

December 13, 2016

#P136F

Revision 02

Applies to Flush doors

CONCEALED VERTICAL ROD/ CABLE EXIT DEVICE APPROVAL FOR 45-, 60-, AND 90-MINUTE POSITIVE PRESSURE FIRE DOORS

The requirements are:

1. 5" legged metal channels at the meeting stiles
2. Top latch bolt lined with intumescent, as supplied by VT (see Figure 1).

Instructions on How to Line Both Edges of the Top CVR Latch with the Provided Intumescent Material

Figure 1

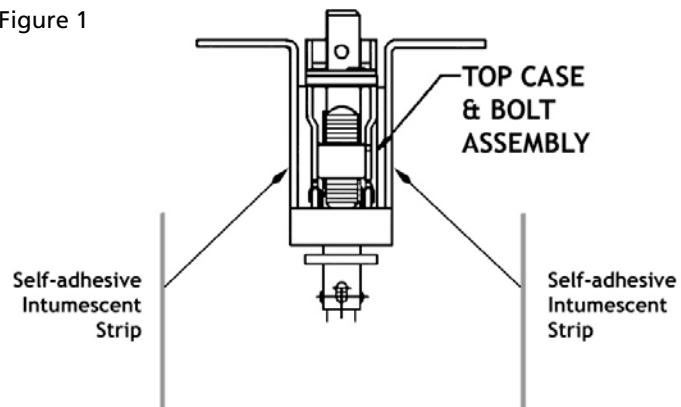

1. Clean any oil, dirt, or residue from the device.
2. Cut or break the intumescent to the correct length.
3. Remove the protective paper backing.
4. Apply the adhesive-backed intumescent to the edges on either side of the CVR top latch as shown.