

## Yankee Stadium

### Project Profile:

The New York Yankees opened their new 51,000-seat home in 2009. The new Yankee Stadium features nearly three times as many luxury suites as the original stadium that was built in 1923. Additional state-of-the-art amenities and unique design features distinguish the ballpark.

### Building Challenge:

The new Yankee Stadium called for doors that would honor the franchise's storied history, while adding a contemporary design aesthetic in its luxury suites and locker room spaces.



Veneer is a signature selection, and complements the walnut in the clubhouse and suites

### VT's Contribution:

VT Industries manufactured 225 flush wood veneer doors for the new stadium. Two distinct types of veneer were specified: figured anigre and black walnut. Both veneers were AA grade and were book- and balance-matched with custom finishes.

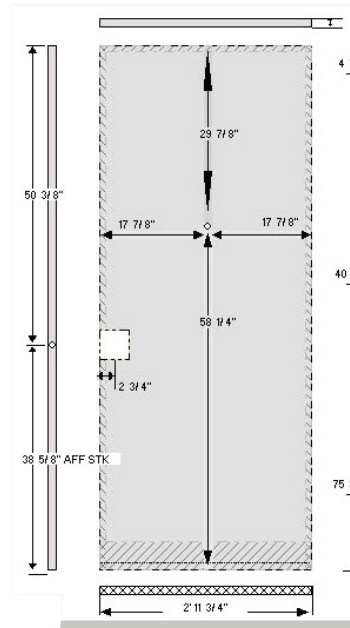

*Wood veneer beauty inspired by heritage and updated with luxury performance*

